

*New*

# Enclosed Loading System Upgrade

for WESTERN STATES 48"x30"/36" and 54"x40" Batch Centrifugals

## Improve Basket Loading, Eliminate Costly Gate Rebuilds, Reduce Sugar Contamination, Enhance Operator Safety

### Old Sliding Load Gate

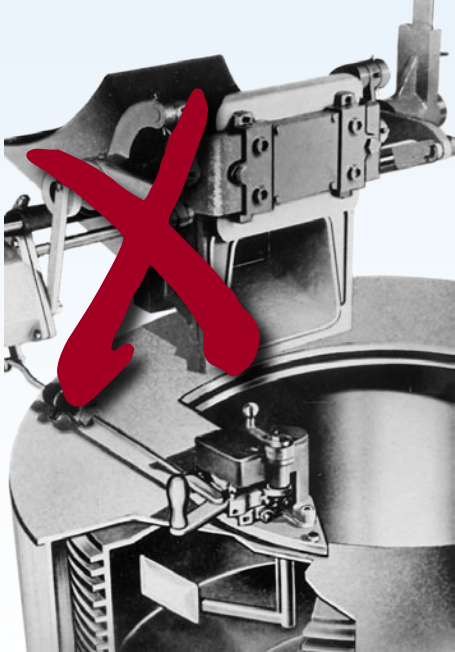

### New Enclosed Loading System

as used on the new TITAN Batch Centrifugals

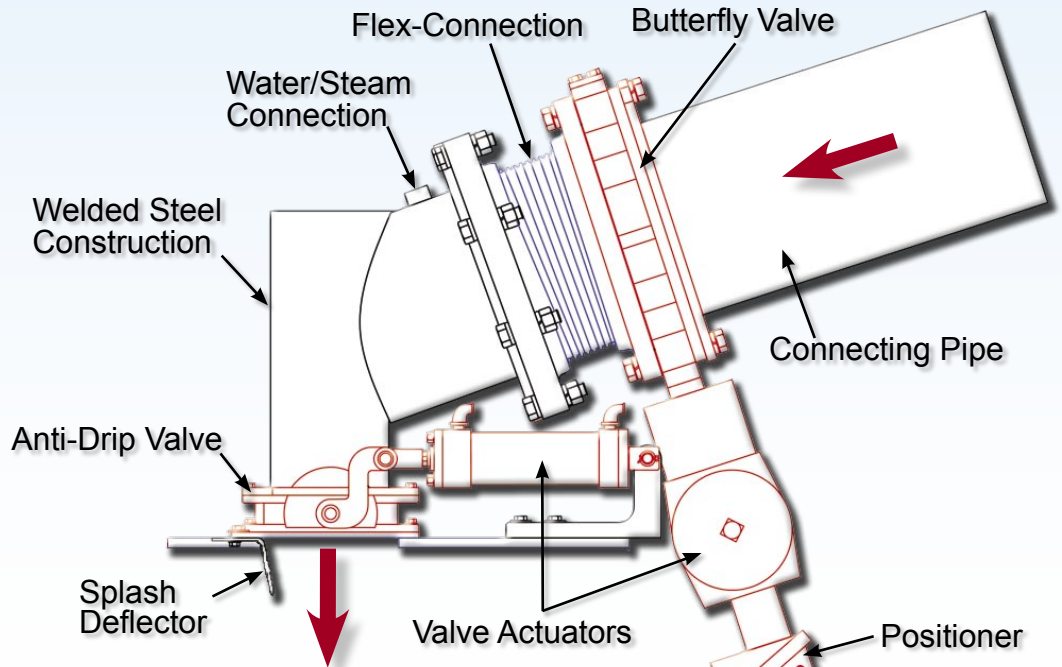

#### BENEFITS:

- Retain Stepped Feed Valve Closing
- More Precise Basket Loading
- Eliminate Costly Gate Rebuilds
- Reduce Sugar Contamination
- Reduce Splashing
- Enhance Operator Safety

#### DESIGN:

- Butterfly Control Valve, 316ss Stem & Disc, EPDM Seat, CI Body, Double Acting Pneumatic Actuator with 4-20ma Positioner
- Flexible Connection Compensates for Thermal Expansion and Vibration
- Welded 304ss Feed Pipe and Transition
- Water/Steam Clean-Out Connection
- Water Tight Anti-Drip Valve, 316ss Disc & Body, Silicone Seat - Pneumatically Actuated
- Curb Top Adaptor Plate (customized to fit individual machine design)
- Masecuite Splash Deflector
- Electromechanical Paddle or Ultrasonic Load Control with 4-20ma signal

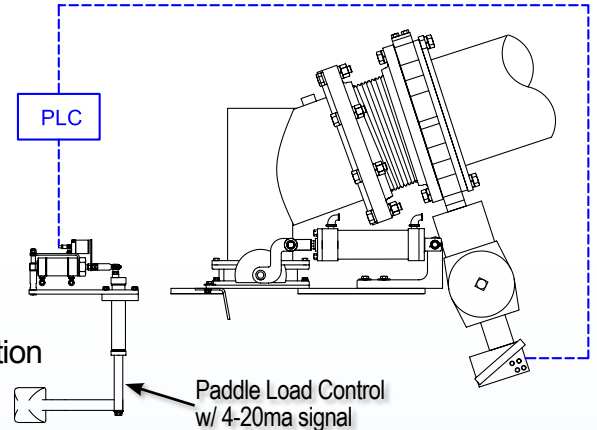
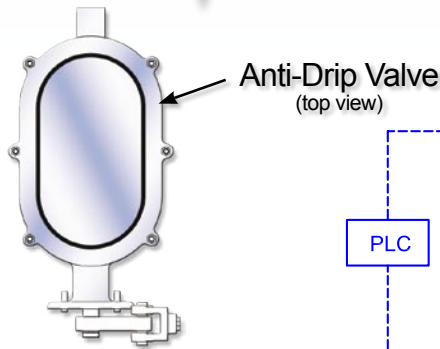

Centrifugal Size	Pipe & Valve Size
48"x30" or 36"	10"
54"x40"	12"



© WSMC 2006

## THE WESTERN STATES MACHINE COMPANY

530 North Third Street, P.O. Box 327, Hamilton, Ohio 45012-0327 U.S.A.

Phone 513.863.4758 · Fax 513.863.3846

sales@westernstates.com · www.westernstates.com

