

New

Enclosed Loading System Upgrade

for WESTERN STATES 48"x30"/36" and 54"x40" Batch Centrifugals

Improve Basket Loading, Eliminate Costly Gate Rebuilds, Reduce Sugar Contamination, Enhance Operator Safety

Old Sliding Load Gate

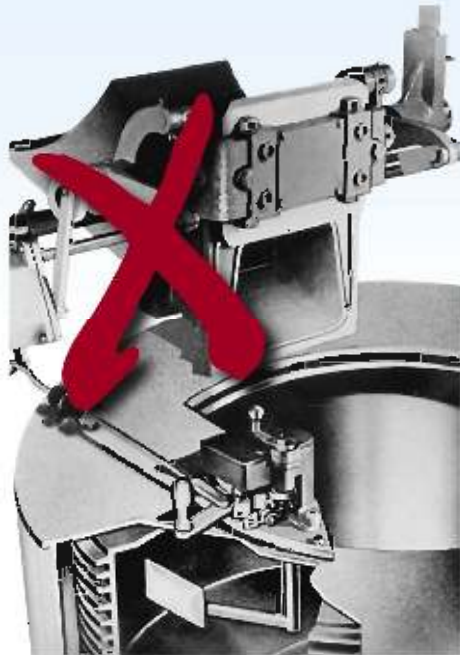

New Enclosed Loading System

as used on the new TITAN Batch Centrifugals

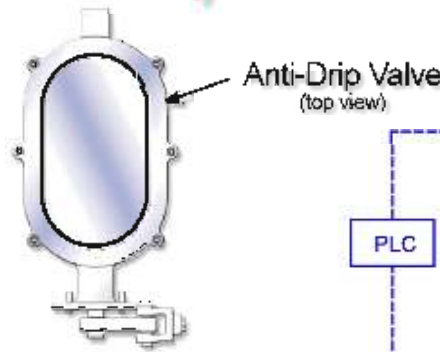
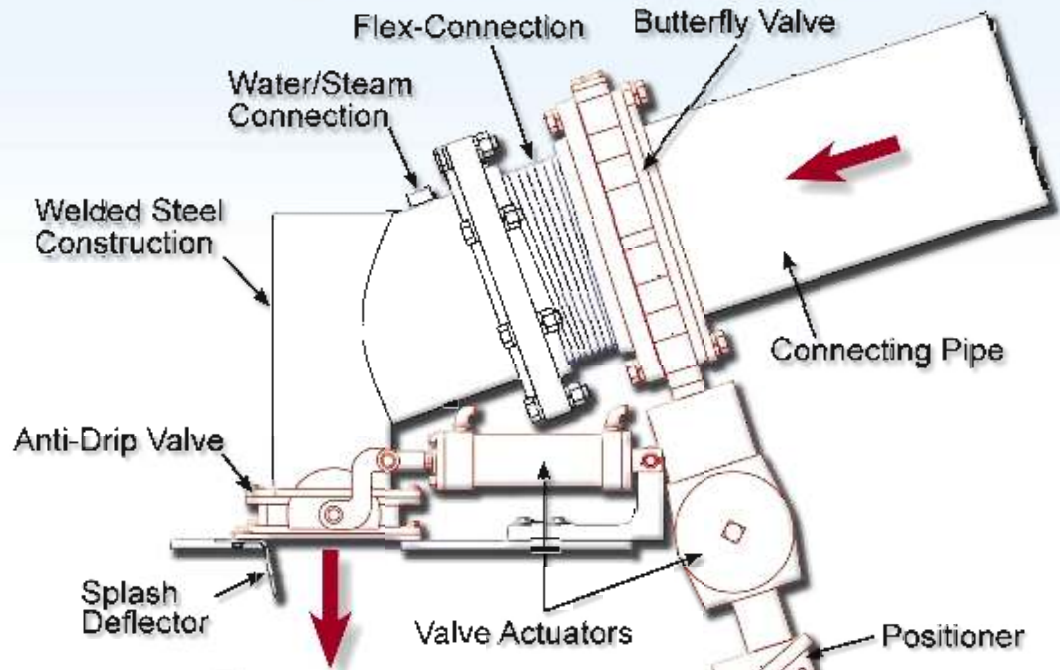

BENEFITS:

- Retain Stepped Feed Valve Closing
- More Precise Basket Loading
- Eliminate Costly Gate Rebuilds
- Reduce Sugar Contamination
- Reduce Splashing
- Enhance Operator Safety

DESIGN:

- Butterfly Control Valve, 316ss Stem & Disc, EPDM Seat, CI Body
Double Acting Pneumatic Actuator with 4-20ma Positioner
- Flexible Connection Compensates for Thermal Expansion and Vibration
- Welded 304ss Feed Pipe and Transition
- Water/Steam Clean-Out Connection
- Water Tight Anti-Drip Valve, 316ss Disc & Body, Silicone Seat - Pneumatically Actuated
- Curb Top Adaptor Plate (customized to fit individual machine design)
- Masecuite Splash Deflector
- Electromechanical Paddle or Ultrasonic Load Control with 4-20ma signal

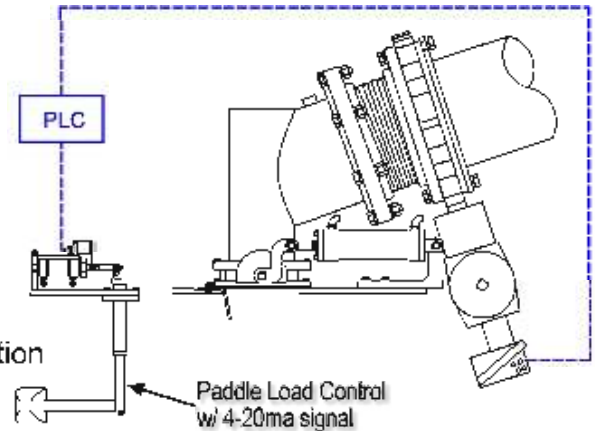

Centrifugal Size	Pipe & Valve Size
48"x30" or 36"	10"
54"x40"	12"



WESTERN STATES

where *innovation happens everyday*



625 Commerce Center Drive
 Fairfield, OH 45011 U.S.A.
 P: 513.863.4758 ~ F: 513.863.3846
www.westernstates.com
innovation@westernstates.com