

MATCH MARKING REPLACEMENT PARTS OF THE LOAD CONTROL UNIT

Refer Figures 1, 2, 3, and 4. The correct springs are three ASC-374-F and they should not be loose. If using an old limiting cam lever (AL-210-G), the old match marks must be removed.

Install the new load control box. Adjust gate adjustment screw (S2) so that stop pin in control box servo lever (AL-204-B) just touches limit switch operating earn (AL-205-B). Refer to Figure 1.

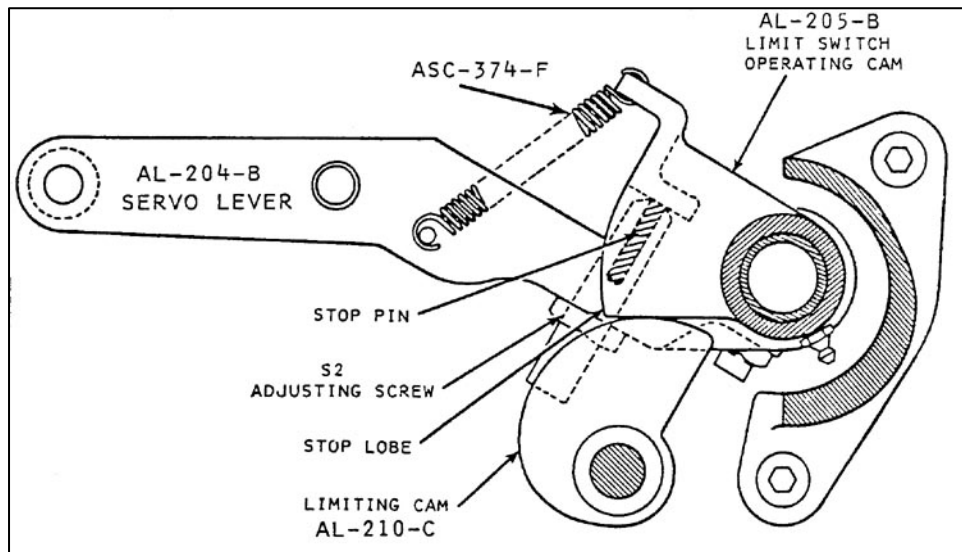

Figure 1

Check length of stop pin. Pin length must be 3/4" long with sliding wedge style gate. Pin length must be 5/8" long with roller wedge style gate.

Refer to Figure 2. Place a straight edge against side of control unit as shown. Using a ruler, align control unit servo lever (AL-204-B) so that it is parallel with rear edge of new loading control box as shown. When AL-204-B is parallel, clamp in place using a "C" clamp. Transfer the existing match mark from "old" servo lever to "new" control box or "old" control box to "new" lever.

NOTE: If a new servo lever and a new control box is used, match mark both the lever and the control box in the parallel position. This set of match marks is referred to as "B". Refer to Figure 2.

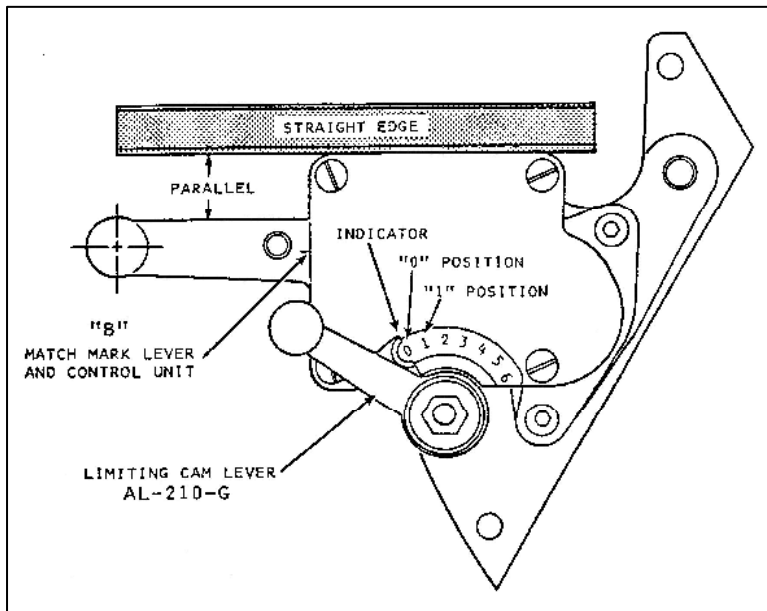

Figure 2

Install limiting earn (AL-210-C) and cam lever (AL-210-G). Rotate limiting cam until it just touches stop lobe of limit switch operating cam (AL-205-B). Refer to Figure 1.

Rotate earn lever (AL-210-G) and align it with the "0" position on scale located on control box cover (AL-202-C) as shown in Figure 2. Using a "C" clamp, clamp cam lever (AL-210-G) and limiting cam (AL-210-C) in this position.

Drill and pin limiting cam to cam lever in this position using a 3/16" dia. steel pin. A new pin hole may have to be drilled. The pin is a press fit in the drilled hole. Refer to Figure 3.

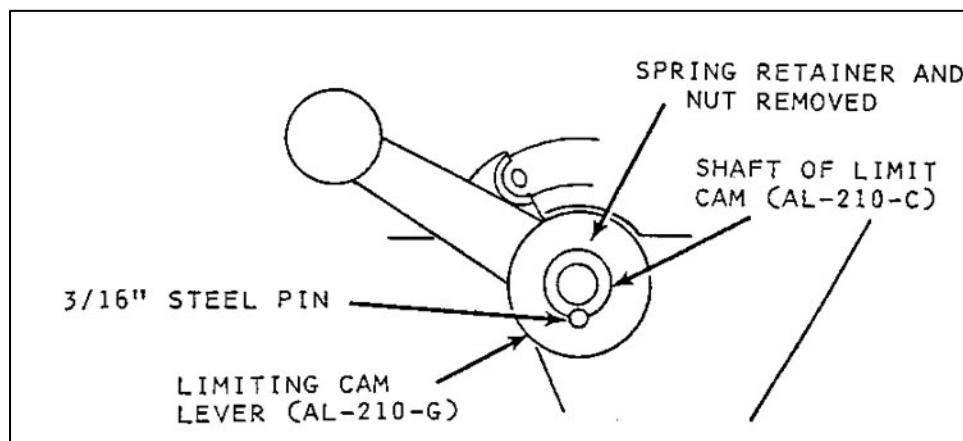

Figure 3

With limiting cam lever (AL-210-G) pinned into position (indicator aligned on "0"), stamp a match mark on the side of the limiting cam lever and mark it "0". Refer to Figure 4. Also stamp a match mark below it on side of control box (AL-210H)

Now adjust cam lever (AL-210-G) so that indicator is aligned with the number 1 position on scale of control box cover. (Refer to Figure 2.) Stamp a match mark on side of limiting cam lever in line with mark previously stamped on side of control box. Label this mark "1". Refer to Figure 4.

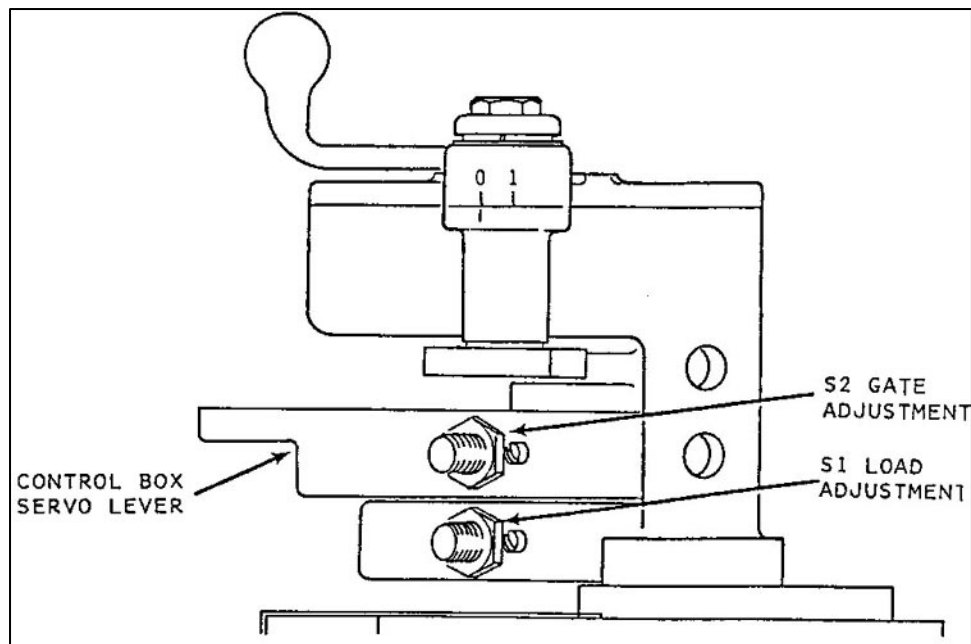

Figure 4